

# VersaTool™

## VT325



The VersaTool™ offers a unique combination of features:

- Power and travel speed to suit varying job conditions and speed productivity
- Choice of cutter drum widths to match applications
- Transport speed (22 MPH) increases production and reduces hauling costs
- Modern cab design enhances operator productivity
- Integral front mounted 400Gal water tank adds weight over cutter drum
- Sonic grade and slope control optional



Standard drum, .76" shank bit on 1/2" lateral spacing

# Maddock

[www.maddockcorp.com](http://www.maddockcorp.com)

Innovative Products to Expand Versatility and Productivity

# VT325 Specifications

## ENGINE

Type ..... John Deere PowerTech  
6081H Turbo-Diesel  
Rated power @2,200 rpm .. 325 bhp  
Displacement ..... 8.1 Liter  
Number of cylinders ..... 6  
Electrical system ..... 24 volt with 80-amp  
alternator

## TRANSMISSION

Type ..... 6-speed PowerShift  
Transmission with  
creeper mode  
Speed Range  
Transit speed ..... 2.0-22.0 mph  
Creeper mode ..... 0.1-2.2 mph

## TIRES:

17.5-25 on 14" rim ..... 20 ply rating, G-3  
Wheel base ..... 220 in.

## BRAKES (Rear axle)

Type ..... Wet oil multi disc,  
service brakes  
Discs per side ..... 3

## OPERATING WEIGHTS (without attachment)

Shipping weight ..... 34,855 Lbs  
Avg. working weight ..... 38,150 Lbs

## ATTACHMENT OPTIONS

Cold Planer  
Lengths ..... 48 inch to 78 inch  
Diameter ..... 34 in.

## CARRIAGE

Horizontal travel ..... 58" Max - side-shift

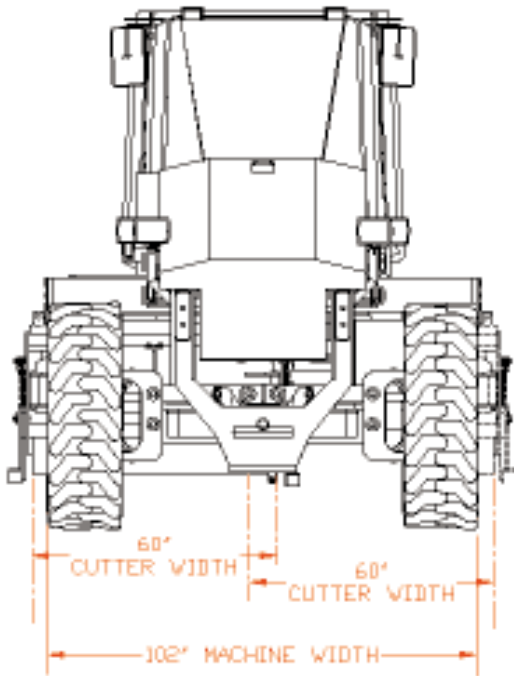

The VersaTool™, equipped with a cold planer, can mill asphalt quickly and precisely. The long wheelbase provides a stable platform for fine grade control and the low range hydrostatic drive allows for infinite adjustment of ground speed to match job conditions. Powered by a 325 Hp. 8.1 Liter diesel the VersaTool is capable of working with cutter drums from 48 to 78 inches. In travel mode the unit can move independently between nearby job sites at speeds up to 22 MPH thus increasing productivity and eliminating the need for costly hauling.

The cutter drum can be side shifted outside the tires on both right and left sides to accommodate various job requirements and allow for milling the complete width of a lane while remaining inside the work lane. Precise shifting of the cutter drum also allows for closer and easier milling near obstructions such as manholes and curbs.

Maddock Industries designs, manufactures and sells mobile construction equipment, attachments, and controls for asphalt road, gravel road, right-of-way maintenance and recycling.



**Warranty:** VersaTool® Model VT325 structure and attachments are warranted for one year against defects in material and workmanship. Hydraulic system is warranted for six months. Warranty covers 100% of parts and labor. Normal wear parts such as cutter bits are not covered. Warranty does not cover damage to cutter head or bits and holder caused by impact with underground objects or damage due to improper operation. Contact Maddock Industries for a copy of the complete warranty.

We reserve the right to make specification, equipment and price changes without notice. Illustrations may include optional equipment and accessories and may not include all standard equipment.

3905 Farmer Avenue, Bloomington, Indiana 47403 (812) 349-3000 [www.maddockcorp.com](http://www.maddockcorp.com)